

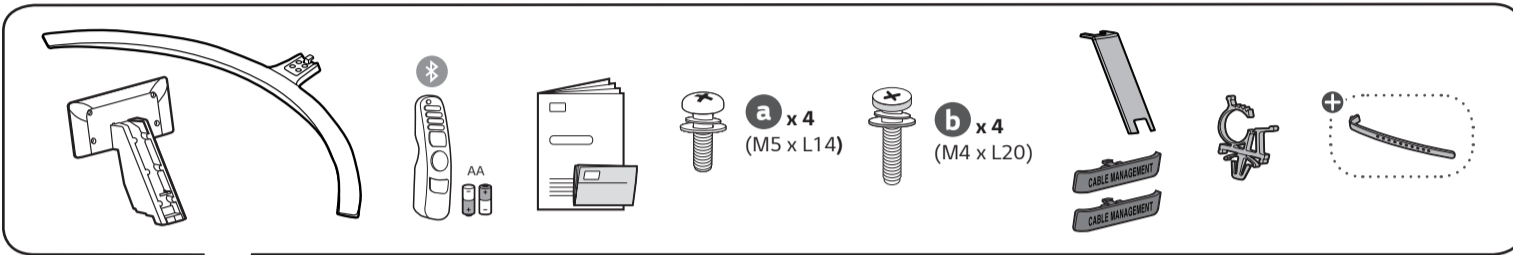

NANO76*

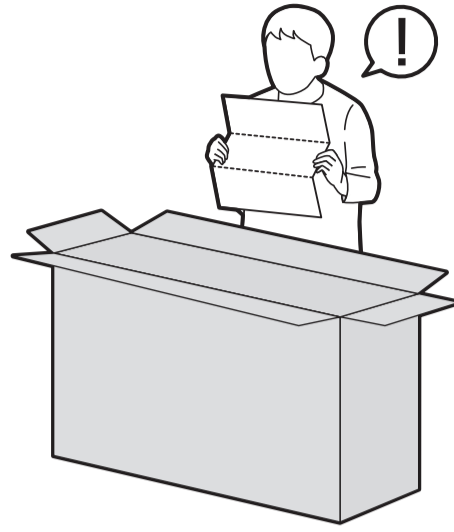

1

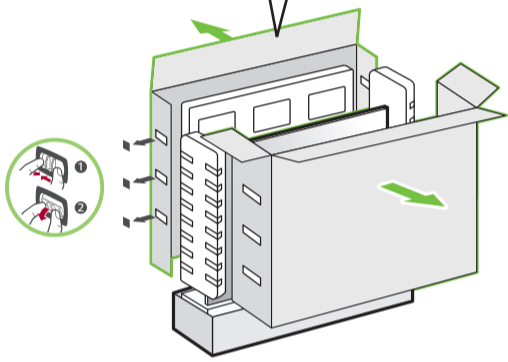

2

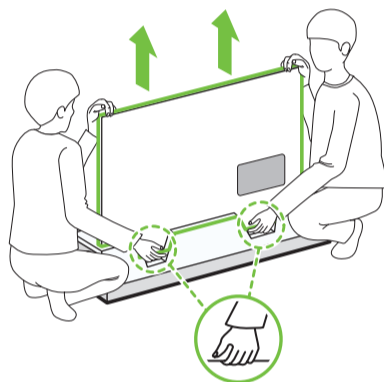

3

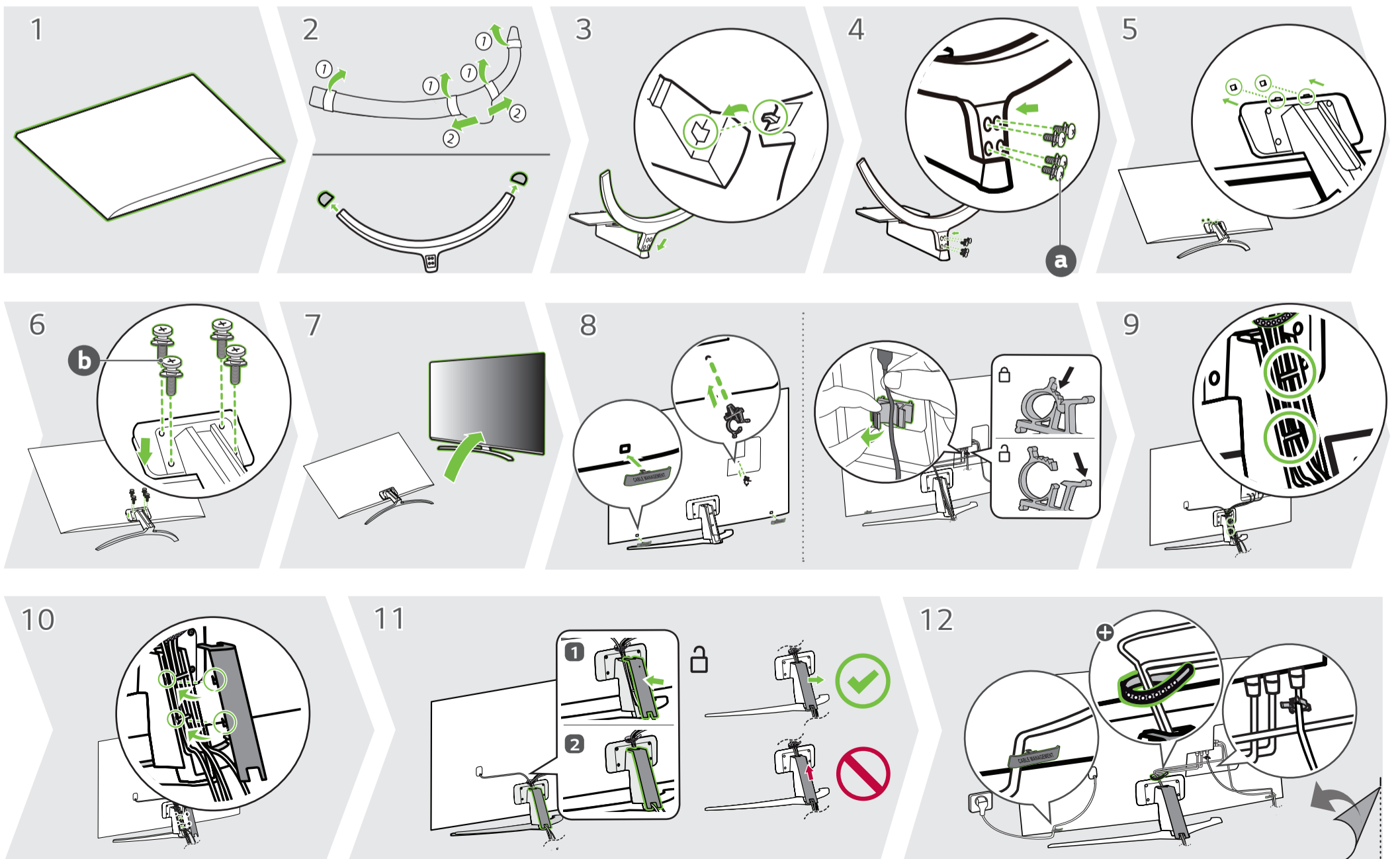
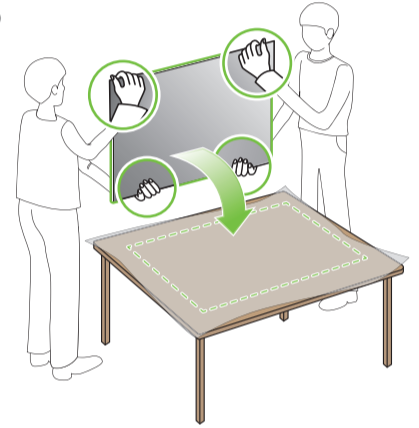

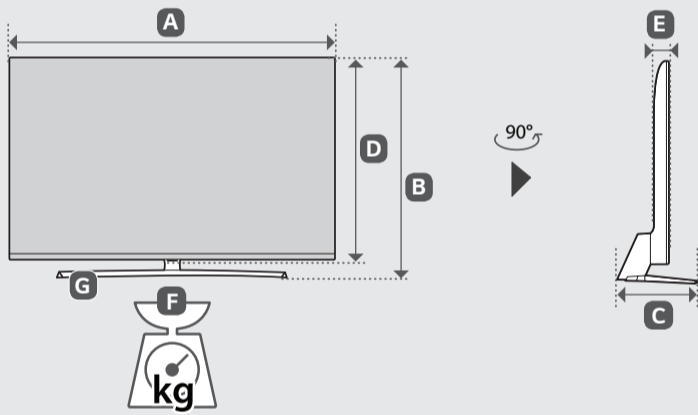
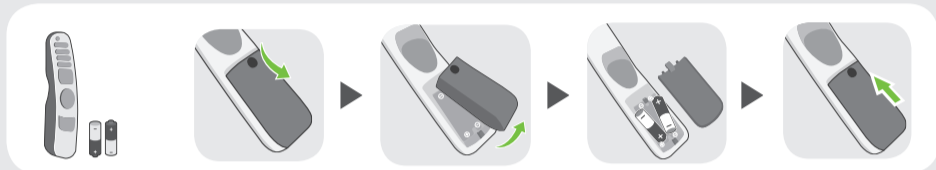
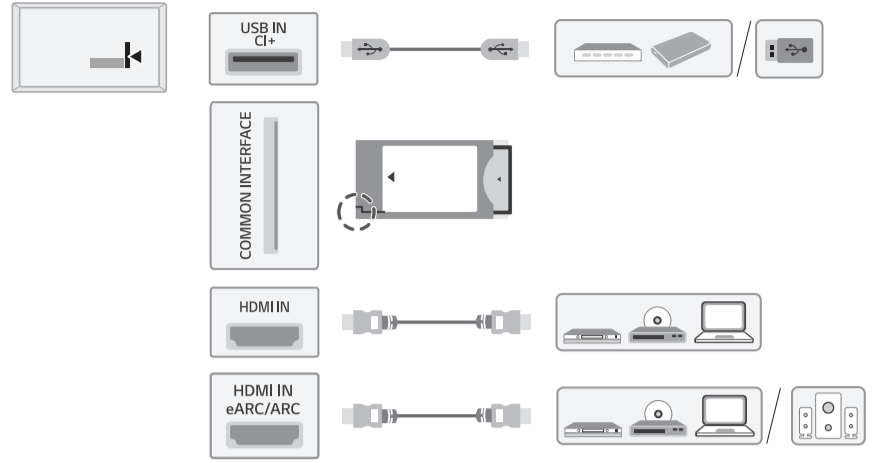
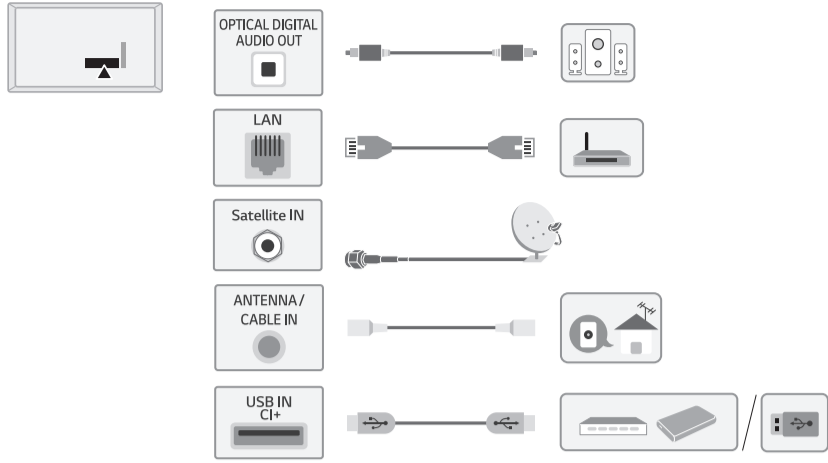

	A	B	C	D	E	F	F-G	
	(mm)					(kg)		
86NANO763QA 86NANO766QA 86NANO769QA	1927	1178	425	1104	59.9	48.9	45.2	
Power requirement	AC 100-240 V ~ 50 / 60 Hz							

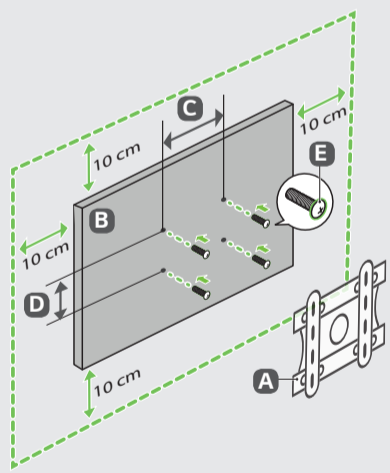

A	B	C x D (mm)	E
LSW640B	86NANO76*	600 x 400	M8



English	•Read Safety and Regulatory.	Hrvatski	•Pročitajte Sigurnost i usklađenost s propisima .	Română	•Consultați manualul referitor la siguranță și reglementare .
Deutsch	•Lesen Sie die Sicherheitsanweisungen und Richtlinien .	Shqip	•Lexoni paragrafin " Siguria dhe rregullimi ".	Български	•Прочетете Безопасност и регулаторни стандарти .
Français	•Lire le document Sécurité et mesures réglementaires .	Bosanski	•Pročitajte dio Sigurnost i propisi .	Eesti	•Lugege ohutus-ja normatiivteavet .
Italiano	•Leggere il manuale Sicurezza e normative .	Македонски	•Прочитajte за безбедноста и регулативата .	Lietuvių k.	•Perskaitykite Saugos ir norminius reikalavimus .
Español	•Leer Seguridad y normativa .	Svenska	•Läs Säkerhet och föreskrifter .	Latviešu	•Izlasiet sadaļu Drošība un normatīvi .
Português	•Ler informações sobre a Segurança e Regulamentos .	Magyar	•Biztonsági szabályzat megtekintése.	Srpski	•Pročitajte odeljak Bezbednost i regulatorna pitanja .
Nederlands	• Veiligheidsinformatie en regelgeving lezen.	Polski	•Prosimy o przeczytanie Zasad bezpieczeństwa i uwag dotyczących przepisów .	Norsk	•Les sikkerhet og forskrifter .
Ελληνικά	•Διαβάστε τις οδηγίες για την ασφάλεια και τους κανονισμούς .	Česky	•Přečtěte si část Bezpečnost a zákonné předpisy .	Dansk	•Læs sikkerhed og lovmæssige bestemmelser .
Slovenščina	•Preberite varnostne in regulativne vidike .	Slovenčina	•Prečítajte si bezpečnostné a regulačné informácie .	Suomi	•Lue Turvallisuus ja säännökset -osio.

⊕ : Depending on model / Abhängig vom Modell / Selon le modèle / In base al modello / En función del modelo / Dependendo do modelo / Afhankelijk van het model / Αν λογα με το μοντ λο / Odvisno od modela / Tipusfüggő / Zależnie od modelu / Závisí na modelu / V závislosti od modelu / În funcție de model / в зависимости от модели / Sõltub mudelist / Priklauso nuo modelio / Atkarībā no modeļa / U zavisnosti od modela / Ovisno o modelu / Në varësi të modelit / Ovisno o modelu / во зависност од моделот / Beroende på modell / Avhengig af modellen / Mallin mukaan